

LED SQUARE DOWN LIGHT

MHTi-DL-SC-4-S SERIES



Project _____

Part Number _____

Quantity _____

DIMENSIONS

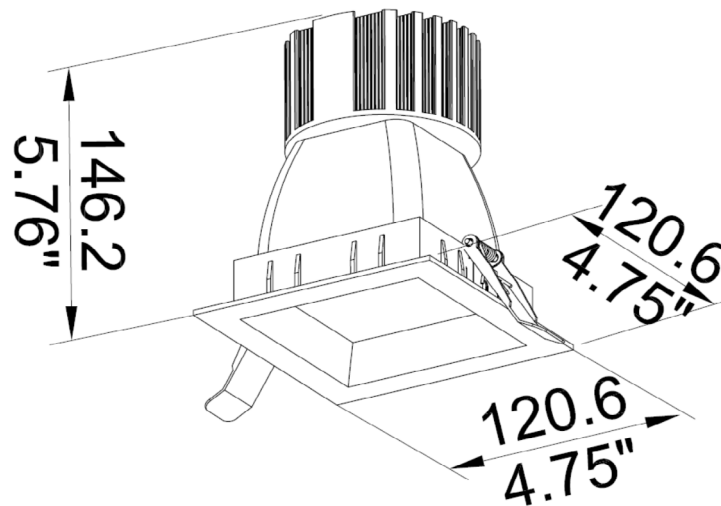

SYSTEM BENEFITS

- Powered by CISCO - PowerWise Category Cable
- Real-time Energy Management
- Monitor Workplace Productivity
- Reduce Installation Time
- Reduce Material Costs
- Space Utilization Reporting
- Daylight Harvesting
- Real-time Security Alerts

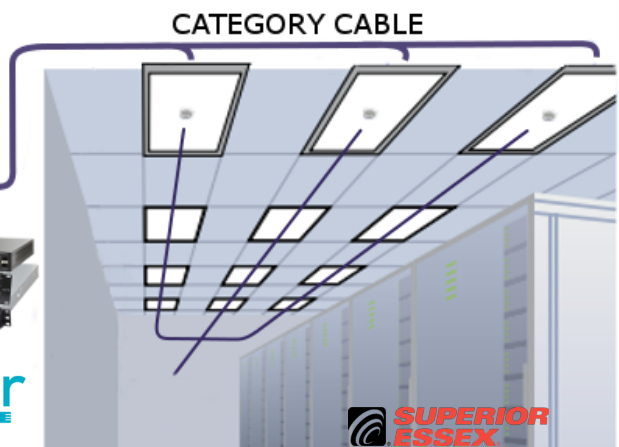

- MHT Products are ETL Listed and Assembled in ISO9000/1 Certified US Facility
- MHT Lighting Offers a 10-year Warranty (See Warranty Terms and Conditions)
- Every Product is Quality Tested and Inspected Prior to Shipment
- Proudly Manufactured in the USA

MHT Manufacturing
1961 Richmond Terrace
Staten Island, New York 10302
Tel: 718.524.4370
Fax: 718.524.4390

West Coast Operations
2285 Michael Faraday Dr. Suite 10
San Diego, California 92154
Tel: 619.661.0600

www.mhtlighting.com
888.511.7780

MHT Confidential
Rev: April 2018