

# INDUCTION FREEZER LIGHT

## MHT-FL SERIES

Project \_\_\_\_\_

Part Number \_\_\_\_\_

Quantity \_\_\_\_\_



### APPLICATIONS

- Freezers
- Cold Storage
- Food, Agriculture



### FEATURES

- >100,000 Hours Rated Lifespan (IESNA)
- 10-year or 60,000 Hours Warranty
- Die Cast Aluminum Housing (Grey)
- Standard Clear Drop Tempered Glass Lens
- Optional UV Stabilized Drop Polycarbonate Lens
- Wall or Ceiling Surface Mount
- Fixture Protection Class IP65
- Ambient Temperature -40 to 120 °F



Polycarbonate Lens

### LAMP/BALLAST

- 120 - 277V Universal Input Voltage
- Optional 347V or 480V
- Available 0-10V Dimming - Minimum 40%
- Power Factor > 0.95, THD < 10%
- 40W-150W Square Tubular Lamp Design
- Instant-On, Flicker Free, Minimum Light Loss
- Color Temperature 3000K/4000K/5000K
- CRI > 85 - Excellent Color Rendition

Model	Rated Wattage	Input Wattage	Replaces	Lamp Lm/W	Lamp Lumen	IP Rating	Size	Lens
MHT-FL-40E	40W	42W	MH - 70W HPS - 70W	80-82	3,200	65	19.7" x 13.8"	Drop Glass, Drop PC
MHT-FL-70E	70W	74W	MH - 100W HPS - 150W	80-82	5,600			
MHT-FL-100E	100W	105W	MH - 175W HPS - 200W	82-85	8,400			
MHT-FL-150E	150W	158W	MH - 250W HPS - 310W	82-85	12,600			



Manufactured in the USA

Toll Free **888-511-7780** • [www.mhtlighting.com](http://www.mhtlighting.com)



# INDUCTION FREEZER LIGHT

## MHT-FL SERIES

Project \_\_\_\_\_

Part Number \_\_\_\_\_

Quantity \_\_\_\_\_

### ORDERING CODES

MHT-FL  E

<u>Wattage:</u>	<u>Color Temp:</u>	<u>Input Voltage:</u>	<u>Lens:</u>	<u>Option:</u>
40, 70,	3K=3000K	U=120~277V	GL=Glass Lens	(Standard in Grey)
100,	4K=4000K	347=208~347V	PL=PC Lens	DB=0-10V Dimming Ballast (Minimum 40%)
150	5K=5000K	480=480V		SPD=Surge Protective Device

### DIMENSIONS

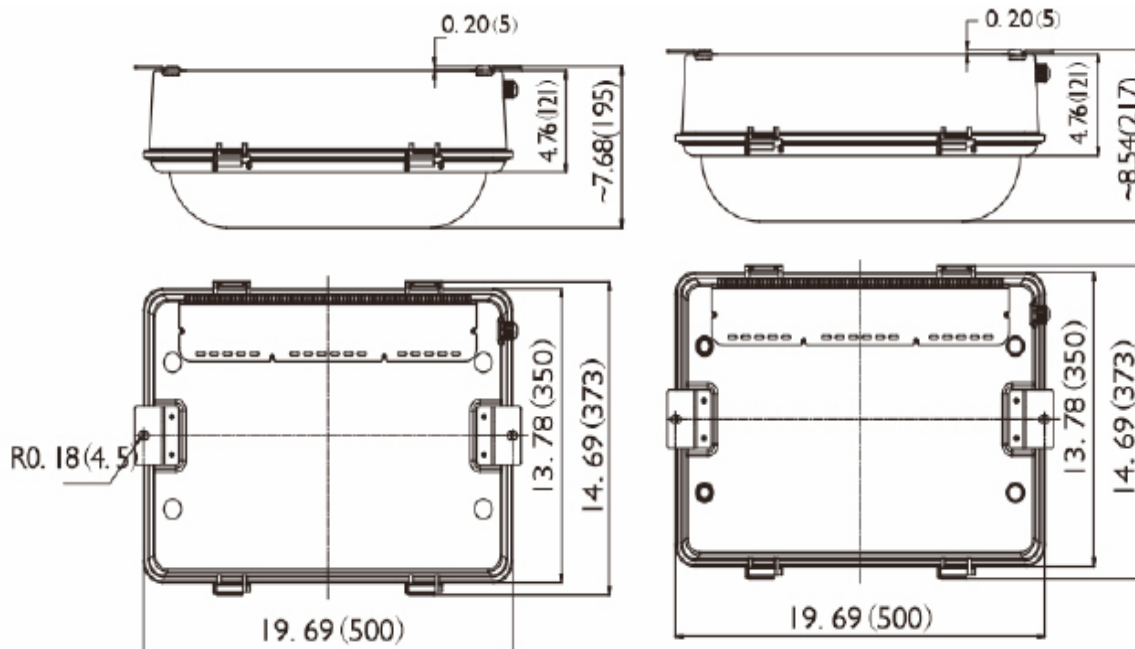

- Standard 1ft Cord from the Side
- Mounting Hole Patterns 19 11/16"; Hole Size 3/16"

- MHT Products are UL Listed and Assembled in ISO9000/1 Certified US Facility
- Every Product is Quality Tested and Inspected Prior to Shipment
- MHT Lighting Offers a 10-year or 60,000 Hours Warranty (See Warranty Terms and Conditions)
- Proudly Manufactured in the USA
- For Product IES Files Please Contact Your Local Rep

#### MHT Plant Operations

1961 Richmond Terrace  
Staten Island, New York 10302  
Tel: (718) 524-4370  
Fax: (718) 524-4390

#### West Coast Operations

2285 Michael Faraday Dr. Suite 10  
San Diego, California 92154  
Tel: (619) 661-0600

[www.mhtlighting.com](http://www.mhtlighting.com)

**888-511-7780**

MHT Confidential  
Rev Date: December 2017