

# LED SURFACE MOUNT TROFFER

## MHTL-SMTR-XC SERIES

Project \_\_\_\_\_

Part Number \_\_\_\_\_

Quantity \_\_\_\_\_



### APPLICATIONS

- Conference/Meeting Room
- Commercial Building
- Healthcare
- Office and School

### FEATURES

- 10-year Warranty
- >100,000 Hours Rated Lifespan
- L70 > 100,000 Hours
- 0.8mm Die-form Steel Housing (White)
- Frosted Prismatic Acrylic Lens - Low Glare & Even Light
- Hinged Doorframe For Easy Installation and Maintenance
- Highly Reflective White Coating to Maximize Efficiency
- Standard Ceiling Surface Mount
- 1/2" Knock-outs on Top



### LED/DRIVER

- Universal Input Voltage 120 - 277V
- Optional Input Voltage 347V/480V
- Power Factor > 0.99 @120V
- THD < 10% @120V
- Surge Protection
- 0-10V Dimmable Driver
- CRI > 80
- Color Temperature 3000K - 5000K

| Model                      | Input Power | Lm/W | Lumen | Dimensions           |
|----------------------------|-------------|------|-------|----------------------|
| MHTL-SMTR-XC-2X2-40E-35K-U | 40W         | 120  | 4,800 | 23.75" x 23.75" x 4" |
| MHTL-SMTR-XC-2X4-50E-35K-U | 50W         | 125  | 6,200 | 23.75" x 47.75" x 4" |
| MHTL-SMTR-XC-2X4-60E-35K-U | 60W         | 125  | 7,500 | 23.75" x 47.75" x 4" |



Manufactured in the USA

Toll Free **888-511-7780** • [www.mhtlighting.com](http://www.mhtlighting.com)



# LED SURFACE MOUNT TROFFER

## MHTL-SMTR-XC SERIES

Project \_\_\_\_\_

Part Number \_\_\_\_\_

Quantity \_\_\_\_\_

### ORDERING CODES

MHTL-SMTR-XC



|                 |                           |                       |                     |
|-----------------|---------------------------|-----------------------|---------------------|
| <u>Wattage:</u> | <u>Color Temperature:</u> | <u>Input Voltage:</u> | <u>Option:</u>      |
| 2X2-40E         | 3K=3000K                  | U=120-277V            | (Standard in White) |
| 2X4-50E         | 35K=3500K                 | 347=347V              |                     |
| 2X4-60E         | 4K=4000K                  | 480=480V              |                     |
|                 | 5K=5000K                  |                       |                     |

### DIMENSIONS

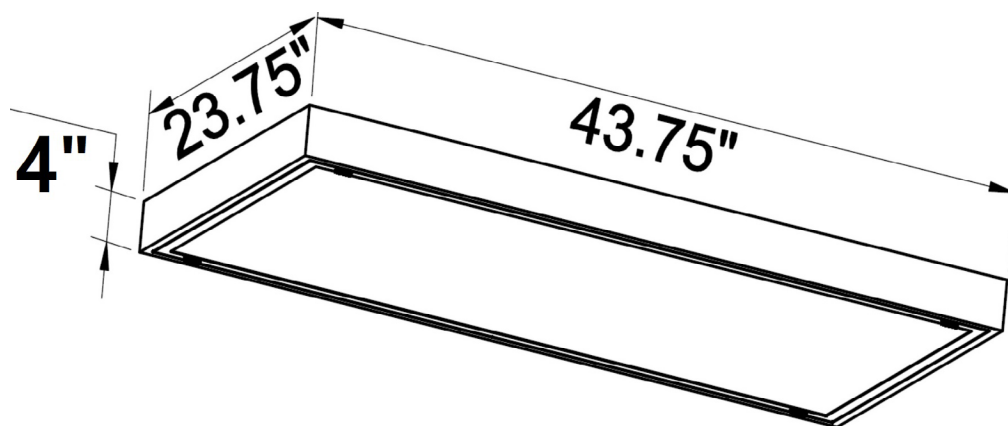
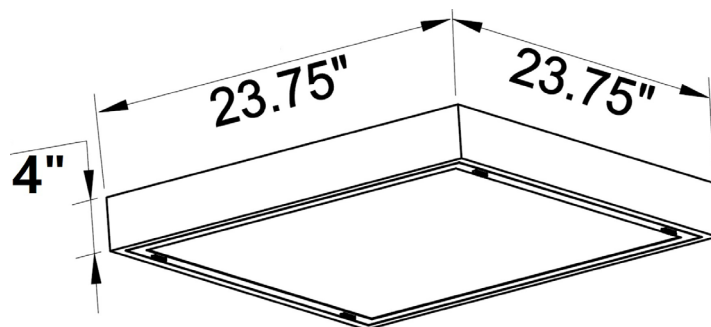

- MHT Products are ETL Listed and Assembled in ISO9000/1 Certified US Facility
- MHT Lighting Offers a 10-year Warranty (See Warranty Terms and Conditions)
- Every Product is Quality Tested and Inspected Prior to Shipment
- Proudly Manufactured in the USA
- For Product IES Files Please Contact Your Local Reps

#### MHT Plant Operations

1961 Richmond Terrace  
 Staten Island, New York 10302  
 Tel: (718) 524-4370  
 Fax: (718) 524-4390

#### West Coast Operations

2285 Michael Faraday Dr. Suite 10  
 San Diego, California 92154  
 Tel: (619) 661-0600

[www.mhtlighting.com](http://www.mhtlighting.com)

**888-511-7780**

MHT Confidential  
 Rev Date: December 2017