

LED STRIP FIXTURE

MHTL-STRP-ECO-XC SERIES

Project _____

Part Number _____

Quantity _____



APPLICATIONS

- Education and Retail
- Healthcare
- Office
- Parking Garage
- Stairwell and Passageway

FEATURES

- >100,000 Hours Rated Lifespan
- 10-year Warranty
- L70 > 75,000 Hours
- 0.8mm Die-form Steel Housing (White)
- Frosted Finish Acrylic Lens
- Highly Reflective White Coating
- 1/2" Knock-out On Each Side and the Back
- Optional Occupancy Sensor
- Optional Emergency Battery Backup
- Standard Surface Mount Ready
- Optional Pendant or Chain Mount Ready



LED/DRIVER

- Universal Input Voltage 120 - 277V
- Optional Input Voltage 347V/480V
- Power Factor > 0.98 @ 120V
- THD < 10% @ 120V
- CRI > 80
- Color Temperature 4000K/5000K
- Surge Protection
- 0-10V Dimmable Driver

Model	Input Power	Lumen	CCT	Dimensions
MHTL-STRP-ECO-XC-2FT-20E-4K-U	20W	2,600	4000K	24" x 3.35" x 3.58"
MHTL-STRP-ECO-XC-4FT-24E-4K-U	24W	3,100	4000K	48" x 3.35" x 3.58"
MHTL-STRP-ECO-XC-4FT-36E-4K-U	36W	4,600	4000K	48" x 3.35" x 3.58"



Manufactured in the USA

Toll Free **888-511-7780** • www.mhtlighting.com



LED STRIP FIXTURE

MHTL-STRP-ECO-XC SERIES

Project _____

Part Number _____

Quantity _____

ORDERING CODES

MHTL-STRP-ECO-XC

	E				
--	---	--	--	--	--

Size & Watt:	Color Temp:	Input Voltage:	Mounting:	Option:
2FT-20	4K=4000K	U=120-277V	SM=Surface	(Standard in White)
4FT-24	5K=5000K	347=347V	PM=Pendant	AC=Adjustable Aircraft Cable (Standard 3ft)
4FT-36		480=480V	CM=Chain Ready	EB=Emergency Battery Backup
				SPD=Surge Protective Device
				OS-On/Off=On/Off Only Motion Sensor
				OS-Dim=Dimming & On/Off Motion Sensor

DIMENSIONS

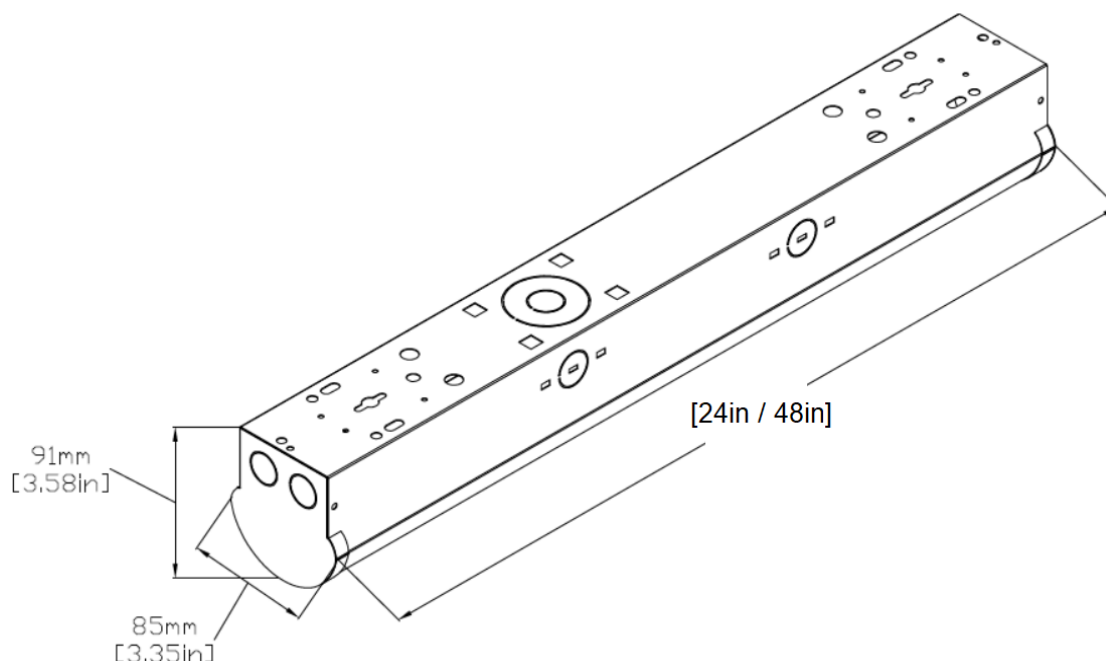

- MHT Products are UL Listed and Assembled in ISO9000/1 Certified US Facility
- MHT Lighting Offers a 10-year Warranty (See Warranty Terms and Conditions)
- Every Product is Quality Tested and Inspected Prior to Shipment
- Proudly Manufactured in the USA
- For Product IES Files Please Contact Your Local Reps

MHT Plant Operations

1961 Richmond Terrace
 Staten Island, New York 10302
 Tel: (718) 524-4370
 Fax: (718) 524-4390

West Coast Operations

2285 Michael Faraday Dr. Suite 10
 San Diego, California 92154
 Tel: (619) 661-0600

www.mhtlighting.com

888-511-7780

MHT Confidential
 Rev Date: December 2017