

LED VAPOR TIGHT MHTL-VT-XC-4FT SERIES

Project _____

Part Number _____

Quantity _____



FEATURES

- 10-year Warranty
- L80 > 78,000 Hours
- Gray Polycarbonate Housing
- Prismatic Polycarbonate Lens
- Eight Stainless Steel Clips
- Standard Surface Mount
- Available Motion Sensor
- Available Integrated Emergency Battery Backup
- IP65 Wet Location Rated

LED/DRIVER

- Universal Input Voltage 120 - 277V
- Optional Input Voltage 347V/480V
- 0-10V Dimmable Driver
- Color Temperature 4000K/5000K

APPLICATIONS

- Parking Garage
- Security Lighting
- Stairwell and Passageway
- Wet Locations



Model	Input Power	CCT	Lm/W	Lumen	Dimensions
MHTL-VT-XC-4FT-40E-5K-U	40W	4000K	>122	>4,500	49.8" x 5.1" x 3.6"

- Power Factor > 0.97 @277V
- THD < 14% @277V
- CRI > 83
- Surge Protection



Manufactured in the USA

Toll Free **888-511-7780** • www.mhtlighting.com



LED VAPOR TIGHT

MHTL-VT-XC-4FT SERIES

Project _____

Part Number _____

Quantity _____

ORDERING CODES

MHTL-VT-XC-4FT E

Wattage: 40
 Color Temperature: 4K=4000K
 5K=5000K
 Input Voltage: U=120-277V
 347=347V
 480=480V
 Option: EM=Emergency Battery Backup
 SPD=Surge Protective Device
 OS-On/Off=On/Off Only Motion Sensor
 OS-Dim=Dimming & On/Off Motion Sensor
 (See "Smart" Series for Details)

All Models in 5000K are DLC Listed Product

DIMENSIONS

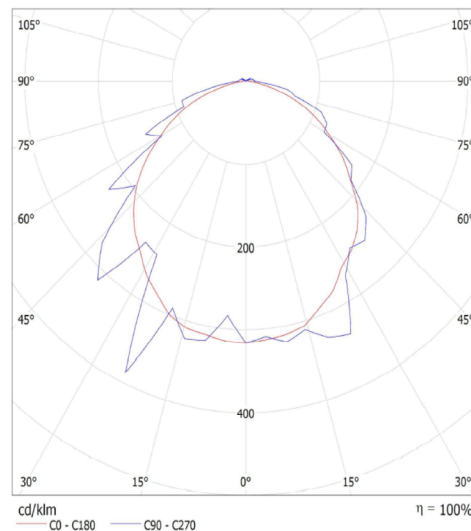
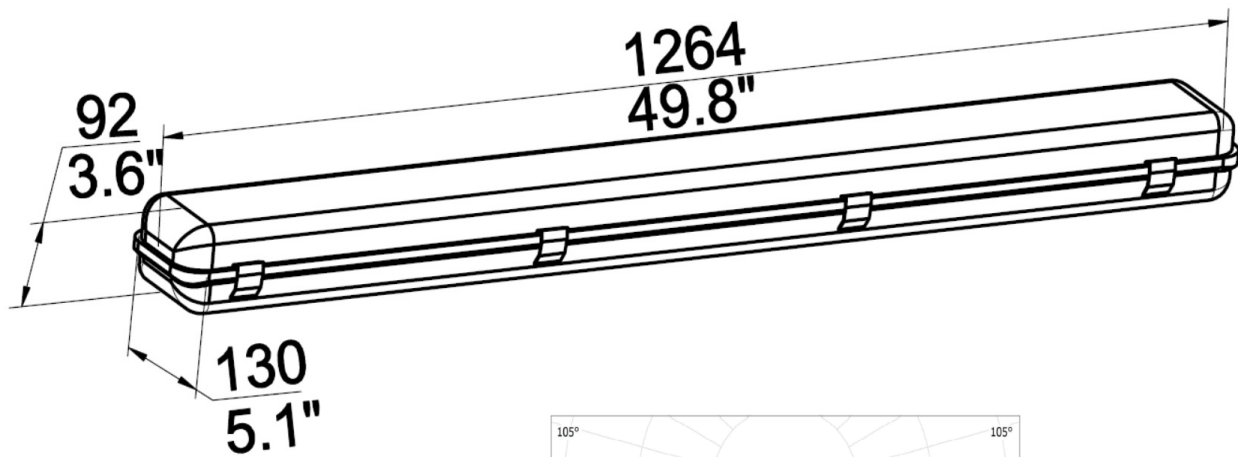

- MHT Products are ETL Listed and Assembled in ISO9000/1 Certified US Facility
- MHT Lighting Offers a 10-year Warranty (See Warranty Terms and Conditions)
- Every Product is Quality Tested and Inspected Prior to Shipment
- Proudly Manufactured in the USA
- For Product IES Files Please Contact Your Local Reps

MHT Plant Operations
 1961 Richmond Terrace
 Staten Island, New York 10302
 Tel: (718) 524-4370
 Fax: (718) 524-4390

West Coast Operations
 2285 Michael Faraday Dr. Suite 10
 San Diego, California 92154
 Tel: (619) 661-0600

www.mhtlighting.com
888-511-7780

MHT Confidential
 Rev Date: December 2017