

# LED TROFFER

## MHTL-VOLS-LD-XC SERIES

Project \_\_\_\_\_

Part Number \_\_\_\_\_

Quantity \_\_\_\_\_



### APPLICATIONS

- Education
- Healthcare
- Office
- Retail

### General Features

- >100,000 hours rated lifespan, L70 > 67,000 hours
- Slim and lightweight housing (White)
- Highly reflective white coating
- Frosted finished polycarbonate lens
- Available integrated emergency battery backup
- Standard grid mount, optional recessed drywall or surface mount
- Lutron LED driver - continuous, flicker-free dimming from 100% to 5% or 100% to 1%
- Guaranteed compatibility with Energi Savr Node™ units with EcoSystem®, GRAFIK Eye® QS with EcoSystem®, PowPak® dimming module with EcoSystem®, and Quantum® systems, allowing for integration into a planned or existing EcoSystem® lighting control solution
- Non-volatile memory restores all settings after power failure
- Protected from miswires of input power to EcoSystem® control inputs up to 277V

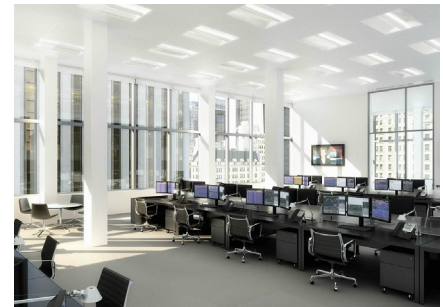

### EcoSystem® Features

- Simpler to wire and more reliable than 0-10V
- Guarantees compatibility between Lutron® controls, drivers, and sensors
- Accommodates zone changing without rewiring
- Link to Lutron® Quantum® Total Light Management System to monitor light power consumption



*Manufactured in the USA*

Toll Free **888-511-7780** • [www.mhtlighting.com](http://www.mhtlighting.com)



# LED TROFFER

## MHTL-VOLS-XC SERIES

Project \_\_\_\_\_

Part Number \_\_\_\_\_

Quantity \_\_\_\_\_

### SPECIFICATIONS

- Universal Input Voltage 120 - 277V
- Operating Frequency 50Hz/60Hz
- CRI > 84
- Power Factor > 0.99 @120V
- THD < 10% @120V
- Color Temperature 3500K/4000K/5000K

Model	Input Power	Lm/W	Lumen	Dimensions
MHTL-VOLS-LD-XC-2X2-24E-4K-U	24W	110	2,600	23.78" x 23.74" x 4.17"
MHTL-VOLS-LD-XC-2X2-40E-4K-U	40W	110	4,000	23.78" x 23.74" x 4.17"
MHTL-VOLS-LD-XC-2X4-36E-4K-U	36W	115	4,600	23.78" x 47.72" x 4.17"
MHTL-VOLS-LD-XC-2X4-50E-4K-U	50W	115	5,700	23.78" x 47.72" x 4.17"

### ORDERING CODES

MHTL-VOLS-LD-XC	Wattage:	Color Temp:	Input Voltage:	Lutron Type:	Option:
	2X2-24E	3K=3000K	U=120-277V	HL=Hi-Lume 1% Dim	(Standard in White)
	2X2-40E	35K=3500K		5S=5-Series 5% Dim	EB=Emergency Battery Backup
	2X4-36E	4K=4000K			FCJ-ECO=Lutron FCJ-ECO
	2X4-50E	5K=5000K			FCJ-010=Lutron FCJ-010

### DIMENSIONS

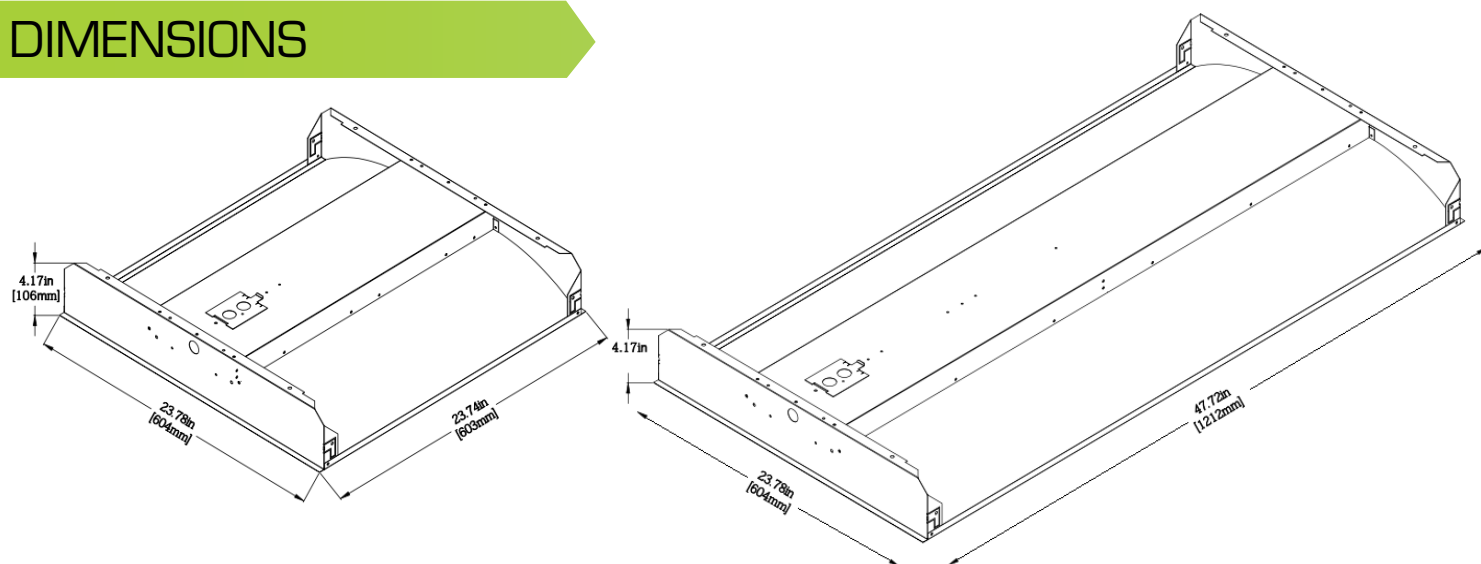

- MHT Products are ETL Listed and Assembled in ISO9000/1 Certified US Facility
- MHT Lighting Offers a 10-year Warranty (See Warranty Terms and Conditions)
- Every Product is Quality Tested and Inspected Prior to Shipment
- Proudly Manufactured in the USA
- For Product IES Files Please Contact Your Local Reps

#### MHT Plant Operations

1961 Richmond Terrace  
Staten Island, New York 10302  
Tel: (718) 524-4370  
Fax: (718) 524-4390

#### West Coast Operations

2285 Michael Faraday Dr. Suite 10  
San Diego, California 92154  
Tel: (619) 661-0600

[www.mhtlighting.com](http://www.mhtlighting.com)

**888-511-7780**

MHT Confidential  
Rev Date: December 2017