

# LED TROFFER

## MHTL-VOL-LD-XC SERIES

Project \_\_\_\_\_

Part Number \_\_\_\_\_

Quantity \_\_\_\_\_



### General Features

- >100,000 hours rated lifespan, L90 > 39,000 hours
- Slim and lightweight housing (White)
- Highly reflective white coating
- Frosted finished polycarbonate lens
- Available integrated emergency battery backup
- Standard grid mount, optional recessed drywall or surface mount
- Lutron LED driver - continuous, flicker-free dimming from 100% to 5% or 100% to 1%
- Guaranteed compatibility with Energi Savr Node™ units with EcoSystem®, GRAFIK Eye® QS with EcoSystem®, PowPak® dimming module with EcoSystem®, and Quantum® systems, allowing for integration into a planned or existing EcoSystem® lighting control solution
- Non-volatile memory restores all settings after power failure
- Protected from miswires of input power to EcoSystem® control inputs up to 277V

### EcoSystem® Features

- Simpler to wire and more reliable than 0-10V
- Guarantees compatibility between Lutron® controls, drivers, and sensors
- Accommodates zone changing without rewiring
- Link to Lutron® Quantum® Total Light Management System to monitor light power consumption

### APPLICATIONS

- Education and Retail
- Healthcare
- Office



*Manufactured in the USA*

Toll Free **888-511-7780** • [www.mhtlighting.com](http://www.mhtlighting.com)



# LED TROFFER

## MHTL-VOL-LD-XC SERIES

Project \_\_\_\_\_

Part Number \_\_\_\_\_

Quantity \_\_\_\_\_

### SPECIFICATIONS

- Universal Input Voltage 120 - 277V
- Operating Frequency 50Hz/60Hz
- CRI > 80
- Power Factor > 0.99 @120V
- THD < 10% @ 120V
- Color Temperature 3000K - 5000K

Model	Input Power	Lm/W	Lumen	Dimensions
MHTL-VOL-LD-XC-2X2-24E-4K-U	24W	123	3,000	23.78" x 23.74" x 2.4"
MHTL-VOL-LD-XC-2X2-38E-4K-U	38W	123	4,400	23.78" x 23.74" x 2.4"
MHTL-VOL-LD-XC-2X4-40E-4K-U	40W	126	5,000	23.78" x 47.72" x 2.4"
MHTL-VOL-LD-XC-2X4-50E-4K-U	50W	126	6,300	23.78" x 47.72" x 2.4"

### ORDERING CODES

MHTL-VOL-LD-XC					
	<u>Wattage:</u>	<u>Color Temp:</u>	<u>Input Voltage:</u>	<u>Lutron Driver:</u>	<u>Option:</u>
	2X2-24E	3K=3000K	U=120-277V	HL=Hi-Lume 1% Dim	(Standard in White)
	2X2-38E	35K=3500K		5S=5-Series 5% Dim	EB=Emergency Battery Backup
	2X4-40E	4K=4000K			FCJ-ECO=Lutron FCJ-ECO
	2X4-50E	5K=5000K			FCJ-010=Lutron FCJ-010

### DIMENSIONS

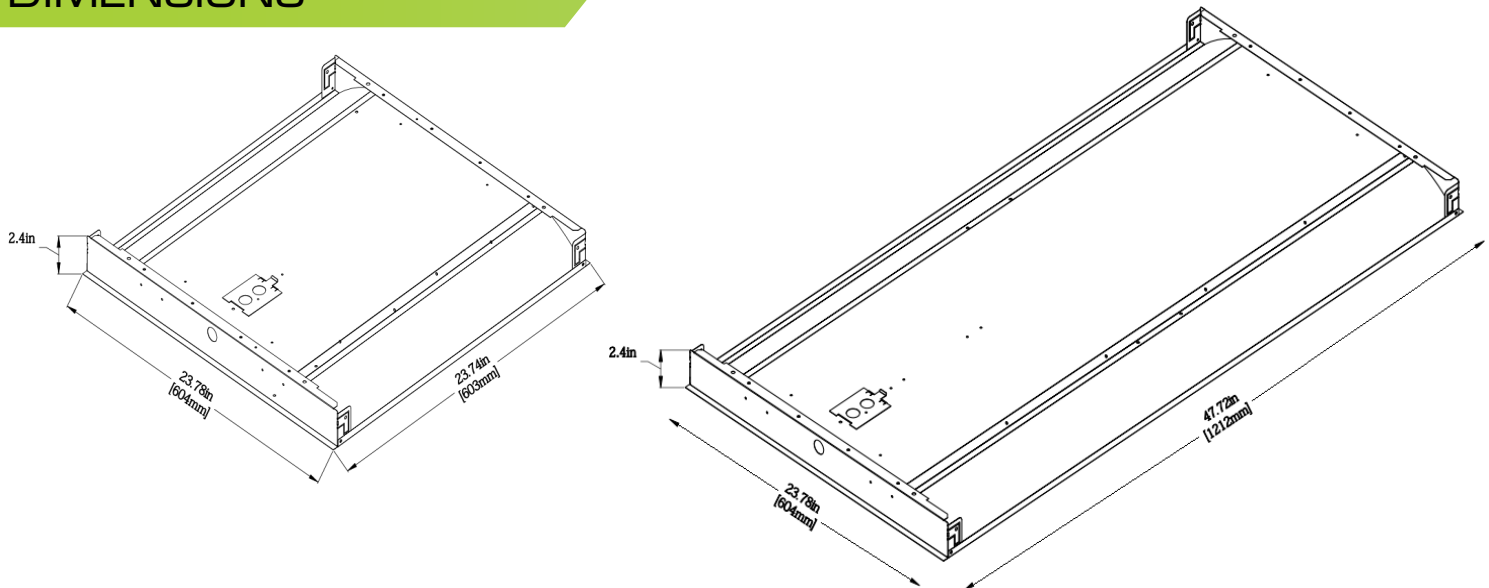

- MHT Products are ETL Listed and Assembled in ISO9000/1 Certified US Facility
- MHT Lighting Offers a 10-year Warranty (See Warranty Terms and Conditions)
- Every Product is Quality Tested and Inspected Prior to Shipment
- Proudly Manufactured in the USA
- For Product IES Files Please Contact Your Local Reps

#### MHT Plant Operations

1961 Richmond Terrace  
Staten Island, New York 10302  
Tel: (718) 524-4370  
Fax: (718) 524-4390

#### West Coast Operations

2285 Michael Faraday Dr. Suite 10  
San Diego, California 92154  
Tel: (619) 661-0600

[www.mhtlighting.com](http://www.mhtlighting.com)

**888-511-7780**

MHT Confidential  
Rev Date: December 2017