

LED VOLUMETRIC TROFFER - SMART

Integrated Controls Solution

MHTL-VOLS-SC SERIES

Project _____

Part No. _____

Quantity _____



APPLICATIONS

- Corporate Campus
- Data Center
- Healthcare



FEATURES

- Title 24 Compliant
- L70 > 68,000 Hours
- Slim and Light Weight Steel Housing
- Frosted Finished Polycarbonate Lens
- Highly Reflective White Coating
- Standard Grid Mount and Surface Mount Option Available
- Integrated Motion Sensor that Reduces Light Output When Unoccupied
- Maximum and Minimum Light Levels Can be Set Based on Applications
- Available to Turn Off When Unoccupied
- Walking Motion Coverage - 36ft Diameter at 9ft Height and 60ft Diameter at 15ft Height
- Available with Integrated Emergency Battery Backup
- Programming Push Button Accessible without Opening Fixture
- "Smart" LED Solutions Offer Incredible Value, Proven Reliability and Are Backed by Our 10-year Warranty
- (See Warranty Terms and Conditions)

LED/DRIVER

- Universal Input Voltage 120 - 277V
- Power Factor > 0.99 @120V
- THD < 10% @120V; CRI > 82
- Color Temperature 3500K/4000K/5000K

Model	Input Power	Lumen	CCT	Dimensions
MHTL-VOLS-SC-2x2-40E-35K-U	40W	>4,500	3500K	23.75" x 23.75" x 4"
MHTL-VOLS-SC-2X4-36E-35K-U	36W	>4,000	3500K	23.75" x 47.75" x 4"
MHTL-VOLS-SC-2X4-36E-4K-U	36W	>4,000	4000K	23.75" x 47.75" x 4"
MHTL-VOLS-SC-2x4-50E-4K-U	50W	>5,600	4000K	23.75" x 47.75" x 4"



Manufactured in the USA

Toll Free **888-511-7780** • www.mhtlighting.com



LED VOLUMETRIC TROFFER - SMART

Integrated Controls Solution

MHTL-VOLS-SC SERIES

Project _____

Part No. _____

Quantity _____

ORDERING CODES

MHTL-VOLS-SC

Wattage: Color Temp: Input Voltage: Mounting: Option:
 2X2-40E=40W 35K=3500K U=120-277V SM=Surface Mount Kit (Standard in White)
 1X4-40E=40W 4K=4000K DK=Recessed Drywall Kit EM=Emergency Backup
 2X4-36E=36W 5K=5000K
 2X4-50E=50W

< Sensor Settings >

Motion Time Delay: Minimum Light Level: Maximum Light Level:
 2.5 to 20 Minutes 10% to 90% / OFF 50% to 100%
Default: 10 Minutes Default: 50% Default: 100%

MHTL-VOLS-2X2-40E-35K-U, MHTL-VOLS-2X4-36E-4K-U, MHTL-VOLS-2X4-50E-4K-U are DLC Listed Products.

DIMENSIONS

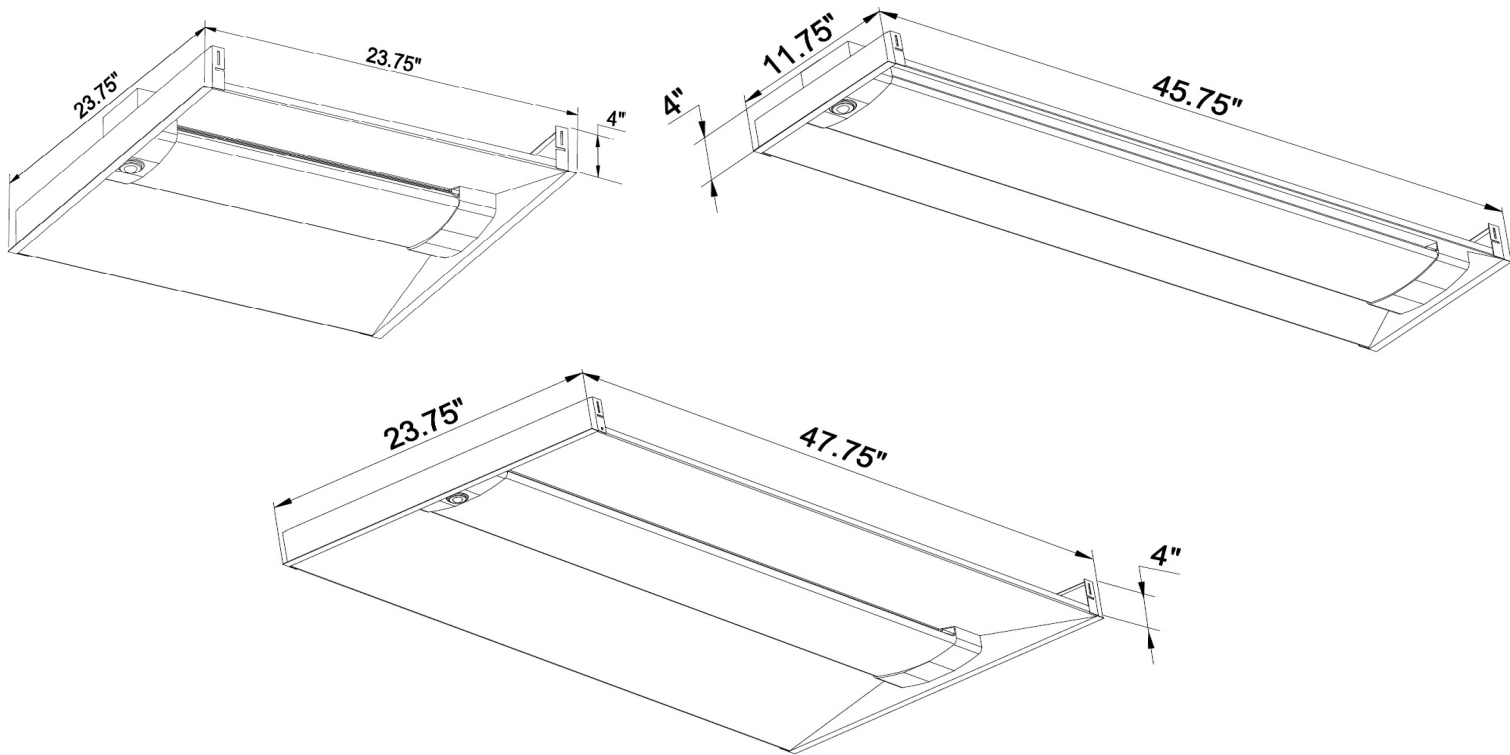

- MHT Products are ETL Listed and Assembled in ISO9000/1 Certified US Facility
- MHT Lighting Offers a 10-year Warranty (See Warranty Terms and Conditions)
- Every Product is Quality Tested and Inspected Prior to Shipment
- Proudly Manufactured in the USA.

MHT Plant Operations

1961 Richmond Terrace
Staten Island, New York 10302
Tel: (718) 524-4370
Fax: (718) 524-4390

West Coast Operations

2285 Michael Faraday Dr. Suite 10
San Diego, California 92154
Tel: (619) 661-0600

www.mhtlighting.com

888-511-7780

MHT Confidential
Rev Date: December 2017