

LED DARKSKY WALLPACK

MHTL-DSWP-XC SERIES

Project _____

Part Number _____

Quantity _____



APPLICATIONS

- Building Exterior
- Parking Garage
- Security Lighting
- Walkway

FEATURES

- >100,000 Hours Rated Lifespan
- 10-year Warranty
- L90 > 90,000 Hours (38W); L90 > 49,000 Hours (76W)
- Die Cast Aluminum Housing (Dark Bronze)
- Standard Flat Clear Tempered Glass Lens
- Optional Polycarbonate Lens - Impact Resistant
- High Performance Acrylic Optical Lens - Type III or IV
- Full Cutoff – Dark Sky Compliant
- Available Integrated Emergency Battery Backup
- Available Integrated Occupancy Sensor - See “Smart” Series



LED/DRIVER

- Universal Input Voltage 120 - 277V
- Optional Input Voltage 347V/480V
- Power Factor > 0.93 @277V
- THD < 20% @277V
- 0-10V Dimmable Driver
- Color Temperature 4000K/5000K
- CRI > 75
- Surge Protection

Model	Input Power	Lumen	CCT	Dimensions
MHTL-DSWP-XC-38E-5K-U	38W	>4,200	5000K	14.25" x 12.13" x 9.17"
MHTL-DSWP-XC-45E-5K-U	45W	>5,000	5000K	14.25" x 12.13" x 9.17"
MHTL-DSWP-XC-76E-5K-U	76W	>8,200	5000K	18.23" x 14.65" x 9.13"



Manufactured in the USA

Toll Free **888-511-7780** • www.mhtlighting.com



LED DARKSKY WALLPACK

MHTL-DSWP-XC SERIES

Project _____

Part Number _____

Quantity _____

ORDERING CODES

MHTL-DSWP-XC	E				
<u>Wattage:</u>	<u>Color Temp:</u>	<u>Input Voltage:</u>	<u>Distribution:</u>	<u>Option:</u>	
38,	4K=4000K	U=120-277V	T3=Type III	(Standard in Dark Bronze)	
45,	5K=5000K	347=347V	T4=Type IV	PR3=3-pin Photocell Receptacle	
76		480=480V		PR7=7-pin Photocell Receptacle	
				PC3=3-pin Photocell	
				PC7=7-pin Photocell	
				SPD=Surge Protective Device	
				EB=Emergency Battery Backup	
				OS-On/Off=On/Off Only Motion Sensor	
				OS-Dim=Dimming & On/Off Motion Sensor	
				(See "Smart" Series For Details)	

MHTL-DSWP-38E and MHTL-DSWP-76E in 4000K are DLC Listed Product

DIMENSIONS

MHTL-DSWP-XC-38E/45E

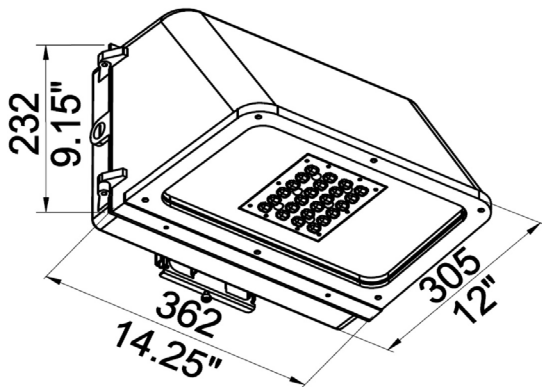

MHTL-DSWP-XC-76E

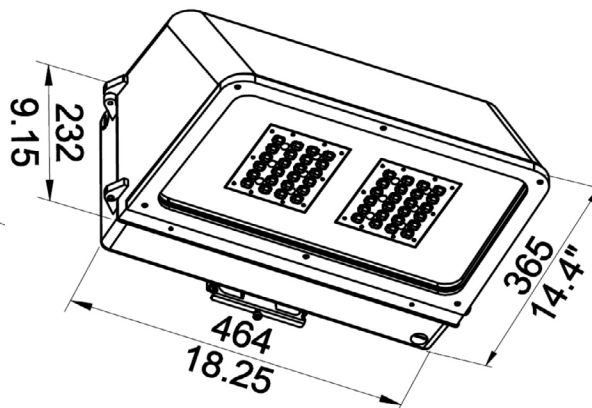

Mounting Plate

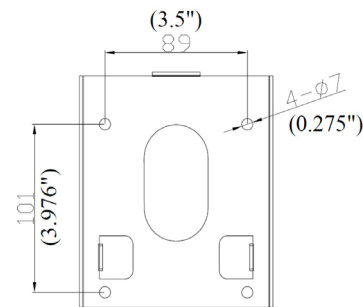

- Mounting Plate Bolt Patterns: 3 1/2" X 4"; Hole Size: 1/4"

- MHT Products are ETL Listed and Assembled in ISO9000/1 Certified US Facility
- MHT Lighting Offers a 10-year Warranty (See Warranty Terms and Conditions)
- Every Product is Quality Tested and Inspected Prior to Shipment
- Proudly Manufactured in the USA
- For Product IES Files Please Contact Your Local Reps

MHT Plant Operations

1961 Richmond Terrace
Staten Island, New York 10302
Tel: (718) 524-4370
Fax: (718) 524-4390

West Coast Operations

2285 Michael Faraday Dr. Suite 10
San Diego, California 92154
Tel: (619) 661-0600

www.mhtlighting.com

888-511-7780

MHT Confidential
Rev Date: December 2017