

# LED TROFFER

## MHTL-VOLS-XC SERIES

Project \_\_\_\_\_

Part Number \_\_\_\_\_

Quantity \_\_\_\_\_



### APPLICATIONS

- Education
- Healthcare
- Office
- Retail

### FEATURES

- >100,000 Hours Rated Lifespan
- 10-year Warranty
- L70 > 67,000 Hours
- Slim and Lightweight Housing
- Frosted Finished Polycarbonate Lens
- Highly Reflective White Coating
- Standard 0-10V Dimmable Driver
- Optional Integrated Occupancy Sensor
- Optional Integrated Emergency Battery Backup
- Standard Grid Mount
- Optional Surface Mount or Recess Drywall



### LED/DRIVER

- Universal Input Voltage 120 - 277V
- Optional Input Voltage 347V/480V
- Operating Frequency 50Hz/60Hz
- CRI > 83
- Power Factor > 0.99 @120V
- THD < 7% @ 120V
- Color Temperature 3500K/4000K/5000K
- 4kV Line to Line Surge Protection

Model	Input Power	Lumen	CCT	Dimensions
MHTL-VOLS-XC-2x2-40E-35K-U	40W	>4,500	3500K	23.75" x 23.75" x 4"
MHTL-VOLS-XC-2X4-36E-35K-U	36W	>4,000	3500K	23.75" x 47.75" x 4"
MHTL-VOLS-XC-2X4-36E-4K-U	36W	>4,000	4000K	23.75" x 47.75" x 4"
MHTL-VOLS-XC-2x4-36E-5K-U	36W	>4,000	5000K	23.75" x 47.75" x 4"
MHTL-VOLS-XC-2x4-50E-4K-U	50W	>5,600	4000K	23.75" x 47.75" x 4"



Manufactured in the USA

Toll Free **888-511-7780** • [www.mhtlighting.com](http://www.mhtlighting.com)



# LED TROFFER

## MHTL-VOLS-XC SERIES

Project \_\_\_\_\_

Part Number \_\_\_\_\_

Quantity \_\_\_\_\_

### ORDERING CODES

MHTL-VOLS-XC	E				
		<u>Wattage:</u>	<u>Color Temp:</u>	<u>Input Voltage:</u>	<u>Mounting:</u>
		2X2-40	35K=3500K	U=120-277V	SM=Surface
		1X4-40	4K=4000K	347=347V	Mount Kit
		2X4-36	5K=5000K	480=480V	DK=Drywall Kit
		2X4-50			
					<u>Option:</u>
					(Standard in White)
					AC=Aircraft Cable (Custom Length)
					EB=Emergency Battery Backup
					OS-On/Off=On/Off Only Motion Sensor
					OS-Dim=Dimming & On/Off Motion Sensor
					(See "Smart" Series Spec Sheet for Details)

MHTL-VOLS-2X2-40E-35K-U, MHTL-VOLS-2X4-36E-4K-U, MHTL-VOLS-2X4-50E-4K-U are DLC Listed Products.

### DIMENSIONS

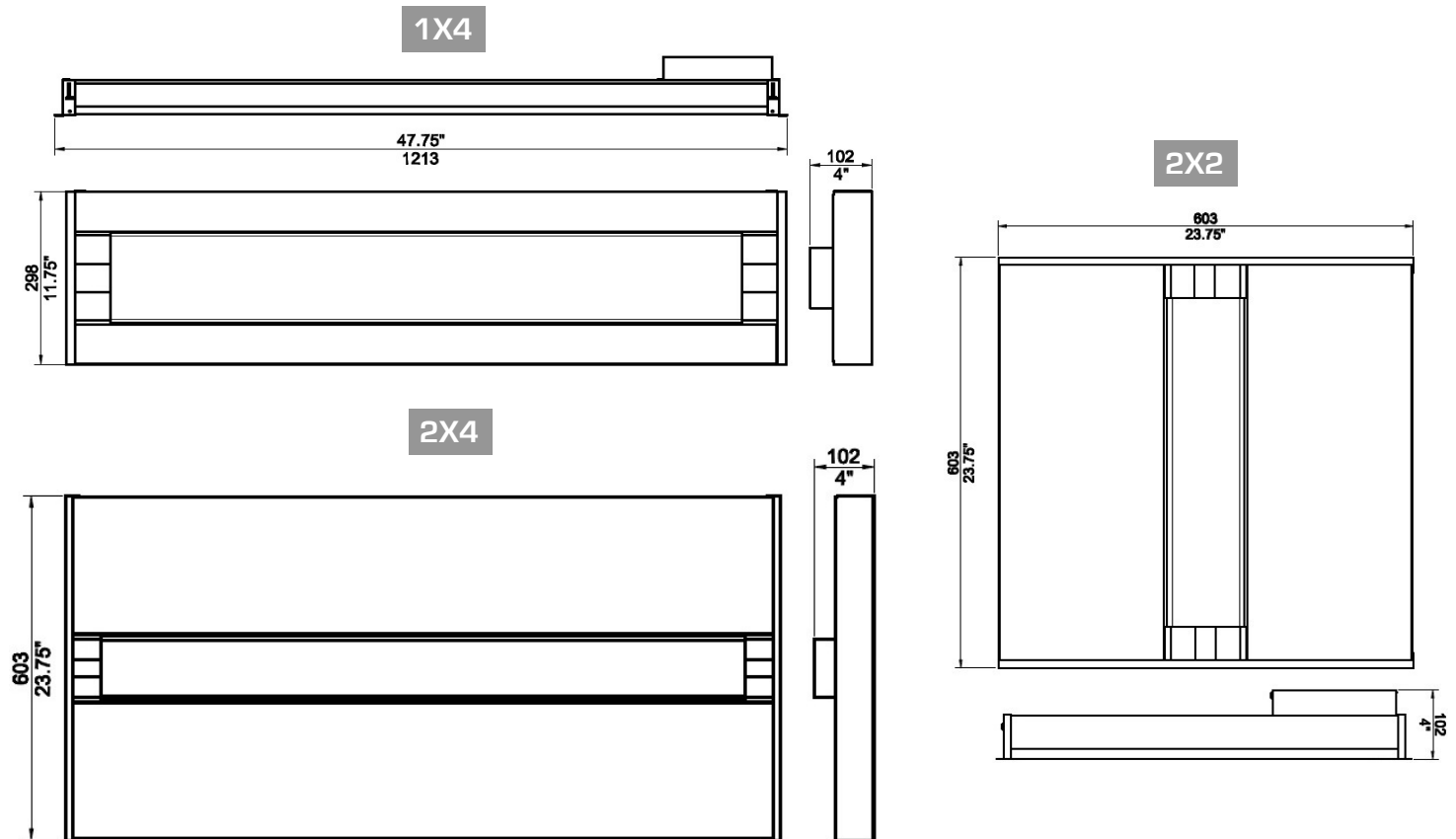

- MHT Products are ETL Listed and Assembled in ISO9000/1 Certified US Facility
- MHT Lighting Offers a 10-year Warranty (See Warranty Terms and Conditions)
- Every Product is Quality Tested and Inspected Prior to Shipment
- Proudly Manufactured in the USA. Meets "Buy American" Requirements within the ARRA
- For Product IES Files Please Contact Your Local Reps

**MHT Plant Operations**  
 1961 Richmond Terrace  
 Staten Island, New York 10302  
 Tel: (718) 524-4370  
 Fax: (718) 524-4390

**West Coast Operations**  
 9543 Heinrich Hertz Dr. Suite 5  
 San Diego, California 92154  
 Tel: (619) 661-0600  
 Fax: (619) 661-0607

[www.mhtlighting.com](http://www.mhtlighting.com)  
**888-511-7780**

MHT Confidential  
 Rev Date: November 2017