

“SMART” LED HIGH BAY / FLOOD

Integrated Controls Solution

MHTL-HF SMART SERIES

Project _____

Part No. _____

Quantity _____

- Maximize efficiency, save on-site labor costs and controls coordination headaches. MHT’s fully integrated photocontrol, occupancy sensor and dimming ability can save up to 90% in energy costs! Making it the “Smart” Solution.

- Our proven “Smart” LED solutions offer incredible value, proven reliability and are backed by our 10-year warranty.



APPLICATIONS

- Convention Center
- Gymnasium
- Manufacturing
- Warehouse

FEATURES

- Attached Motion Sensor that Reduces Light Output When An Area is Unoccupied
- Dimming Range Between 10% and 50% (or Turns OFF) When Motion is Not Detected
- Different Lens Options for Open Area or Aisleway
- L70 > 75,000 Hours; Title 24 Compliant
- Die Cast Aluminum Driver and Wiring Compartment (Matte White)
- Highly Efficient Aluminum Extrusion Heat Sink
- Standard Hook Mount or 3/4” Pendant
- Optional Yoke Mount for Flood Applications
- Available in 15°, 40° or 110° Distribution
- Fixture Protection Class IP65



LED/DRIVER

- Standard Input Voltage 120/277V
- Power Factor > 0.95 @277V
- THD < 15% @277V
- Color Temperature 4000K/5000K
- 6kV Surge Protection
- CRI > 75

Model	Input Power	Lm/W	Lumen	Dimensions
MHTL-HF-140E-4K-U	140W	110	15,000	12” x 11.4” x 12.8”
MHTL-HF-210E-4K-U	210W	110	23,000	17” x 11.4” x 12.8”
MHTL-HF-260E-4K-U	260W	110	28,000	25.3” x 11.4” x 14”
MHTL-HF-325E-4K-U	325W	110	35,000	25.3” x 11.4” x 14”



Manufactured in the USA

Toll Free **888-511-7780** • www.mhtlighting.com



"SMART" LED HIGH BAY / FLOOD

Integrated Controls Solution

MHTL-HF SMART SERIES

Project _____

Part No. _____

Quantity _____

ORDERING CODES

MHTL-HF **E**

<u>Wattage:</u> 140, 210, 260, 325	<u>Color Temp:</u> 4K=4000K 5K=5000K	<u>Input Voltage:</u> U=120/277V 347=347V	<u>Distribution:</u> 15=15° 40=40° 110=110°	<u>Mounting:</u> PM=Pendant (Standard 3/4") YM=Yoke Mount	<u>Option:</u> (Standard in Matte White) AC=Aircraft Cable CP=Cord & Plug (Specify Cord & Plug) SPD=Surge Protective Device
--	--	---	--	--	---

< Sensor Settings >

<input type="text"/>	<input type="text"/>	<input type="text"/>
<u>Motion Sensor Lens Option:</u> 360=360° (45ft Height, 60ft Diameter Coverage) AW=Aisleway (40ft Height, 100ft x 5ft Linear Coverage)	<u>Dimming Level:</u> 10 to 50% or Disable Default: 50%	<u>Hold Time:</u> 1 to 20 Minutes Default: 3 Minutes

Hold Time - Time period for fixture remains at 100% output after motion is not detected

Dimming Level - Fixture Light level after **Hold Time** (Disable - Fixture goes OFF after **Hold Time**)

DIMENSIONS

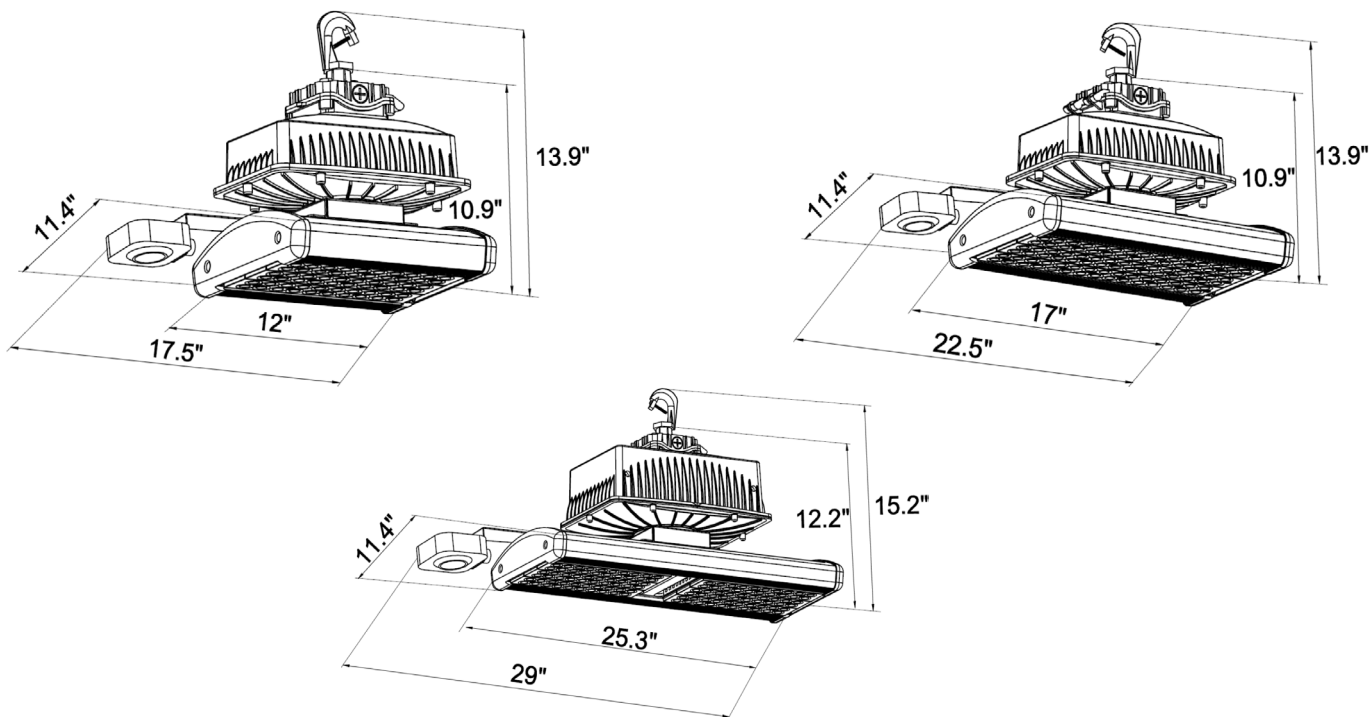

- MHT Products are ETL Listed and Assembled in ISO9000/1 Certified US Facility
- MHT Lighting Offers a 10-year Warranty (See Warranty Terms and Conditions)
- Every Product is Quality Tested and Inspected Prior to Shipment
- Proudly Manufactured in the USA
- For Product IES Files Please Contact Your Local Reps

MHT Plant Operations

1961 Richmond Terrace
Staten Island, New York 10302
Tel: (718) 524-4370
Fax: (718) 524-4390

West Coast Operations

2285 Michael Faraday Dr. Suite 10
San Diego, California 92154
Tel: (619) 661-0600

www.mhtlighting.com

888-511-7780

MHT Confidential
Rev Date: December 2017