

LED DIRECT-LIT PANEL - SMART

Integrated Controls Solution

MHTL-PAN-DIR-SC SERIES

Project _____

Part No. _____

Quantity _____



APPLICATIONS

- Corporate Campus
- Data Center
- Healthcare

FEATURES

- Title 24 Compliant
- L70 > 67,000 Hours
- Slim and Light Weight Steel Housing
- Frosted Finished Acrylic Lens
- Highly Reflective White Coating
- Standard Grid Mount and Surface Mount Option Available
- Integrated Motion Sensor that Reduces Light Output When Unoccupied
- Maximum and Minimum Light Levels Can be Set Based on Applications
- Available to Turn Off When Unoccupied
- Walking Motion Coverage - 36ft Diameter at 9ft Height and 60ft Diameter at 15ft Height
- Available with Integrated Emergency Battery Backup
- Programming Push Button Accessible without Opening Fixture
- "Smart" LED Solutions Offer Incredible Value, Proven Reliability and Are Backed by Our 10-year Warranty - (See Warranty Terms and Conditions)



LED/DRIVER

- Universal Input Voltage 120 - 277V
- Power Factor > 0.99 @120V
- THD < 10% @120V; CRI > 82
- Color Temperature 3500K/4000K/5000K

Model	Input Power	Lumen	Dimensions
MHTL-PAN-DIR-SC-2X2-38E-35K-U	38W	4,200	23.75" x 23.75" x 1.8"
MHTL-PAN-DIR-SC-2X4-53E-35K-U	53W	6,000	47.75" x 23.75" x 1.8"



Manufactured in the USA

Toll Free **888-511-7780** • www.mhtlighting.com



LED DIRECT-LIT PANEL - SMART

Integrated Controls Solution

MHTL-PAN-DIR-SC SERIES

Project _____

Part No. _____

Quantity _____

ORDERING CODES

MHTL-PAN-DIR-SC	<input type="text"/>	<input type="text"/>	<input type="text"/>	<input type="text"/>	<input type="text"/>	<input type="text"/>
Wattage:	Color Temp:	Input Voltage:	Mounting:	Option:		
2X2-38E=38W	35K=3500K	U=120-277V	SM=Surface Mount	[Standard in White]		
2X4-53E=53W	4K=4000K		DK=Drywall Kit	EB=Emergency Backup		
	5K=5000K					
				< Sensor Settings >		
	<input type="text"/>	<input type="text"/>	<input type="text"/>			
Motion Time Delay:	Minimum Light Level:	Maximum Light Level:				
2.5 to 20 Minutes	10% to 90% / OFF	50% to 100%				
Default: 10 Minutes	Default: 50%	Default: 100%				

MHTL-PAN-DIR-2X4-53E-4K-U is DLC Listed Product

DIMENSIONS

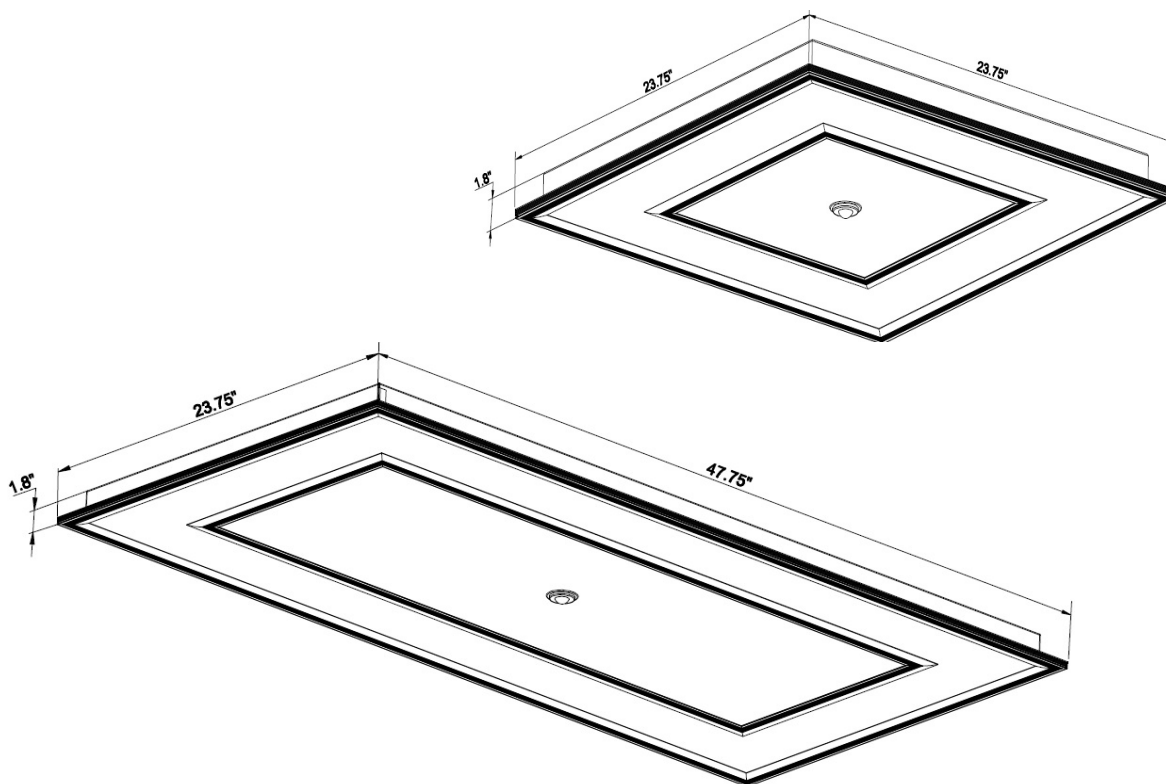

- MHT Products are ETL Listed and Assembled in ISO9000/1 Certified US Facility
- MHT Lighting Offers a 10-year Warranty (See Warranty Terms and Conditions)
- Every Product is Quality Tested and Inspected Prior to Shipment
- Proudly Manufactured in the USA

MHT Plant Operations

1961 Richmond Terrace
 Staten Island, New York 10302
 Tel: (718) 524-4370
 Fax: (718) 524-4390

West Coast Operations

2285 Michael Faraday Dr. Suite 10
 San Diego, California 92154
 Tel: (619) 661-0600

www.mhtlighting.com

888-511-7780

MHT Confidential
 Rev Date: December 2017